

Product overview

The Viconics R820 series SCR power controls are designed for cost effective, precise modulation of electric loads for most electric heating applications.
(Applicable on resistive loads only)

The R820 series consists of SCR's power controls, c/w factory assembled heatsink for surface or in-panel mounting.



Models available

Model No.	Voltage Range	Phase	Max Current
R820-211-REV2	24 - 240 Volts AC	1	10 Amp
R820-213-REV2	24 - 240 Volts AC	3	10 Amp
R820-321-REV2	24 - 347 Volts AC	1	25 Amp
R820-323-REV2	24 - 347 Volts AC	3	25 Amp
R820-341-REV2	24 - 347 Volts AC	1	45 Amp
R820-343-REV2	24 - 347 Volts AC	3	45 Amp
R820-421-REV2	24 - 480 Volts AC	1	25 Amp
R820-423-REV2	24 - 480 Volts AC	3	25 Amp
R820-441-REV2	24 - 480 Volts AC	1	45 Amp
R820-443-REV2	24 - 480 Volts AC	3	45 Amp
R820-471-REV2	24 - 480 Volts AC	1	75 Amp
R820-621-REV2	24 - 600 Volts AC	1	25 Amp
R820-623-REV2	24 - 600 Volts AC	3	25 Amp
R820-641-REV2	24 - 600 Volts AC	1	45 Amp
R820-643-REV2	24 - 600 Volts AC	3	45 Amp
R820-671-REV2	24 - 600 Volts AC	1	75 Amp

Features

Feature	Benefit
⇒ Complete assembly with factory installed heat sink.	⇒ Reduced total installation cost
⇒ Designed for surface or panel mounting	⇒ Covers wider array of application with same component.
⇒ UL Recognized	⇒ Easily integrated into complete assembly requiring industry listings.
⇒ CSA approved for Canada and USA	⇒ Trouble free approval process
⇒ Status LED	⇒ Quick field troubleshooting.
⇒ High quality assembly with 2 year warranty	⇒ Reduced field service calls.
⇒ Full line of matching peripheral temperature controllers	⇒ Simplified component sourcing and matching for reliable operation

They are compatible with many industry standard signals. A typical application would be to control a modulating electric duct heater with a 0 to 10 Vdc control signal from an analog room thermostat. The R820 power controller also contain four dip switch to adjust to the following control signals:

- 0 to 10 Vdc control signal (2 to 10 Vdc control range)
- 4 to 20 mA control signal
- 0 to 135 Ω control signal

Power modules installation

Important.

All external safety devices like: contactors, relays, flow switch & thermal protections are to be supplied and installed by other.

When the SCR is installed inside a panel, the enclosure needs to be adequately louvered for proper ventilation and heat dissipation. Call the factory for the derating amperage curves for these specific applications.

Electronic controls require special care for wiring and startup. To avoid problems, carefully follow the procedures below.

Look at the wiring diagrams, and study them carefully. Be sure that you understand how the system is supposed to work.

A) Location:

- 1- Can be installed inside a louvered approved cabinet or with the heatsink mounted externally.
- 2- Must be installed away from excessive heat source.
- 3- Nothing must restrain air circulation to the heatsink.

B) Installation:

- 1- If installed completely inside a cabinet, use the mounting tabs on the heatsink to secure the SCR to the back plate of the panel.
- 2- If installed with heatsink outside the cabinet, use the proper model mounting template for the cut out dimensions and to check for mounting obstructions.
- 3- Respect mounting orientation (this side up).
- 4- Mount the heatsink vertically on the side of the cabinet for proper heat dissipation.
- 5- Do not relocate the power switching modules on the heatsink.

R820 Installation and Dimensions

- Mounting instructions & templates are available from the factory.
- The cutout templates include holes position for heatsink attachment to the electrical cabinet
 - ❖ Single phase R820 will have 2 mounting screw, 1 on each side.
 - ❖ Three phase R820 will have 4 mounting screw, 2 on each side.
- Respect mounting orientation (this side up).
- Mount the heatsink vertically on the side of the cabinet for proper heat dissipation.
- If mounted on top or bottom of the cabinet, derate maximum usable amperage by 25%
- Do not relocate the power switching modules on the heatsink.

R820 single phase	A	B	C	D	E	Weight
R820-211-REV2	5.25 "	4.50 "	2.56"	3.00 "	3.75 "	1.80
R820-321-REV2	5.25 "	4.50 "	2.56"	3.00 "	3.75 "	1.80
R820-341-REV2	5.25 "	6.50 "	2.56"	3.00 "	3.75 "	2.40
R820-421-REV2	5.25 "	4.50 "	2.56"	3.00 "	3.75 "	1.80
R820-441-REV2	5.25 "	6.50 "	2.56"	3.00 "	3.75 "	2.40
R820-471-REV2	5.25 "	10.00 "	2.56"	3.00 "	3.75 "	3.50
R820-621-REV2	5.25 "	4.50 "	2.56"	3.00 "	3.75 "	1.80
R820-641-REV2	5.25 "	6.50 "	2.56"	3.00 "	3.75 "	2.40
R820-671-REV2	5.25 "	10.00 "	2.56"	3.00 "	3.75 "	3.50

R820 three phase	A	B	C	D	E	Weight
R820-213-REV2	5.25 "	6.50 "	2.56"	3.00 "	5.75 "	2.60
R820-323-REV2	5.25 "	6.50 "	2.56"	3.00 "	5.75 "	3.70
R820-343-REV2	5.25 "	10.00 "	2.56"	3.00 "	5.75 "	3.70
R820-423-REV2	5.25 "	6.50 "	2.56"	3.00 "	5.75 "	2.65
R820-443-REV2	5.25 "	10.00 "	2.56"	3.00 "	5.75 "	3.70
R820-623-REV2	5.25 "	6.50 "	2.56"	3.00 "	5.75 "	2.65
R820-643-REV2	5.25 "	10.00 "	2.56"	3.00 "	5.75 "	3.70

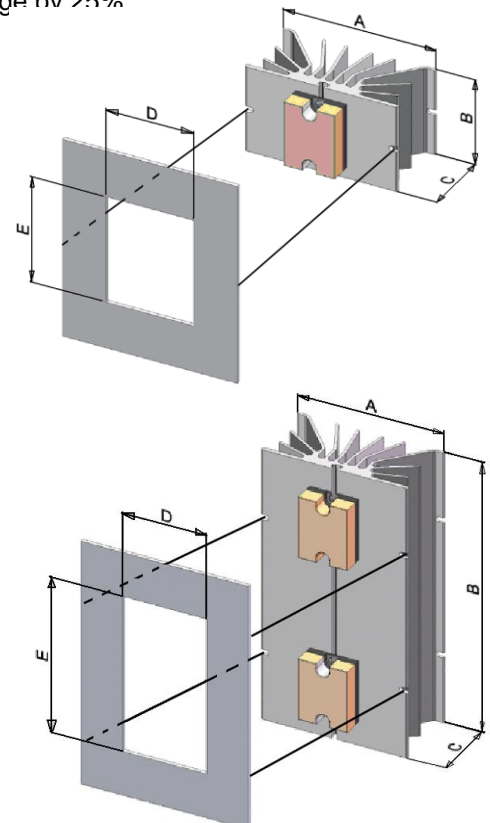

DIP Switch Adjustments per applications

INPUT SIGNAL	SWITCH #1	SWITCH #2	SWITCH #3	SWITCH #4
0 to 10 Vdc control signal (2 to 10 Vdc control range)	Off	Off	Off	On
4 to 20 mA control signal	Off	Off	On	Off
0 to 135 Ω control signal	On	On	Off	Off

Typical applications

0 To 10 Vdc Room Or Duct Thermostat Control

Dip switch position	S1	S2	S3	S4
0 to 10 Vdc control signal	Off	Off	Off	On

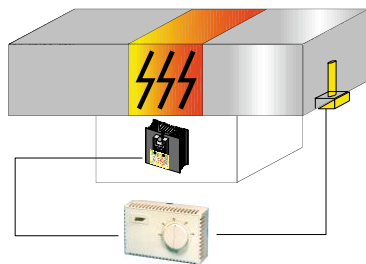
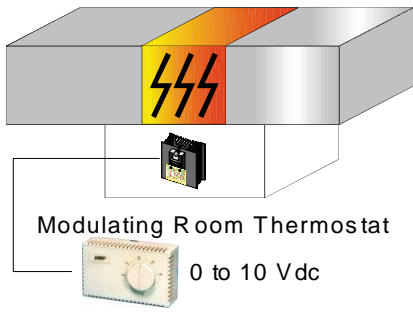

2 Vdc = 0% capacity
10 Vdc = 100% capacity

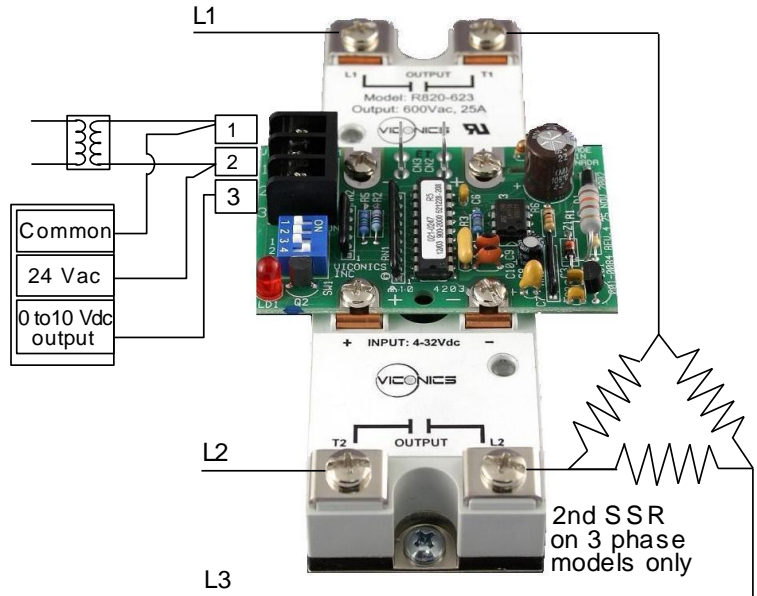

0 To 10 Vdc From a Building Automation System

Dip switch position	S1	S2	S3	S4
0 to 10 Vdc control signal	Off	Off	Off	On

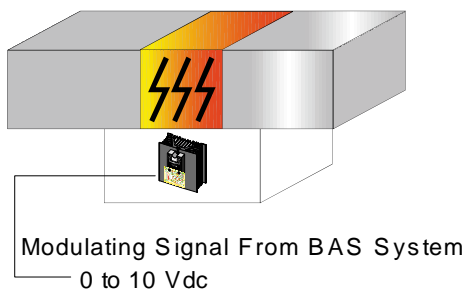

2 Vdc = 0% capacity
10 Vdc = 100% capacity

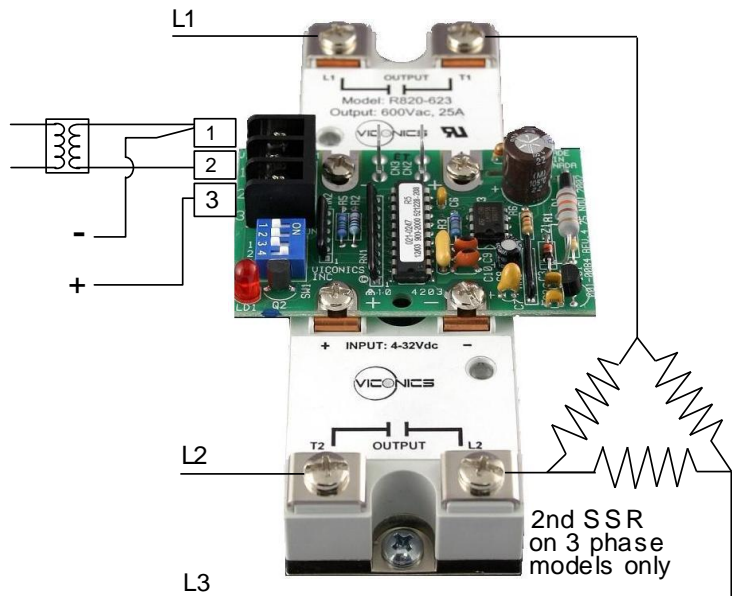

0 To 135 Ω Room Or Duct Thermostat Control

Dip switch position	S1	S2	S3	S4
0 to 135 Ω control signal	On	On	Off	Off

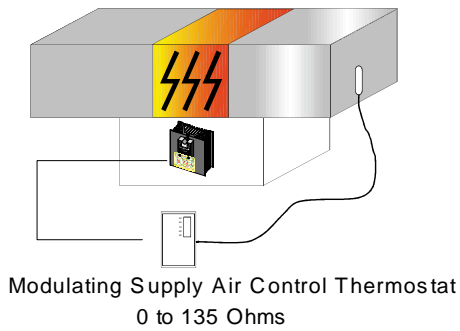
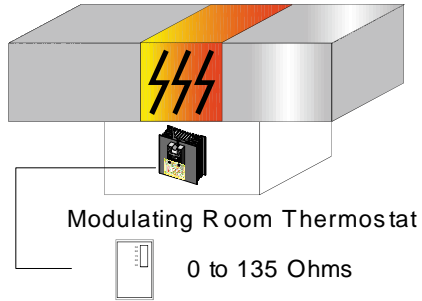

0 Ohms = 0% capacity
135 Ohms = 100% capacity

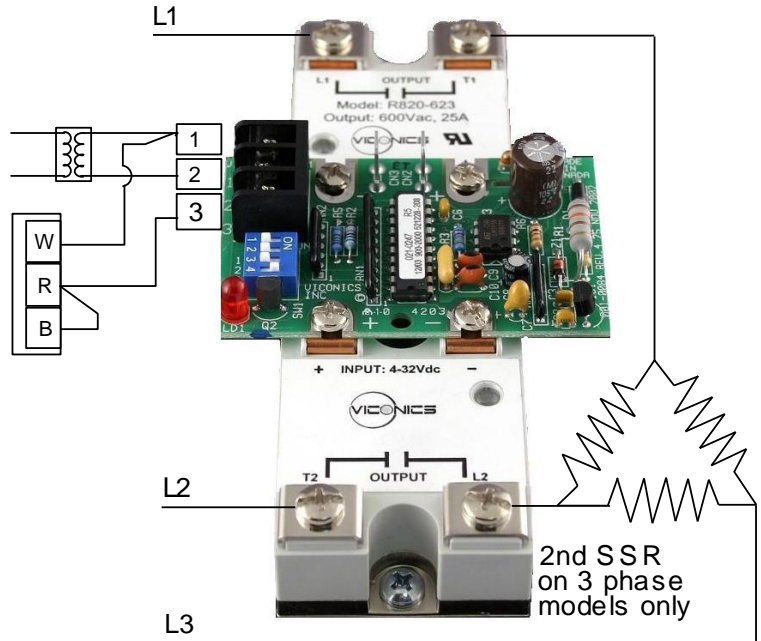

4 To 20 mA From a Building Automation System

Dip switch position	S1	S2	S3	S4
4 to 20 mA control signal	Off	Off	On	Off

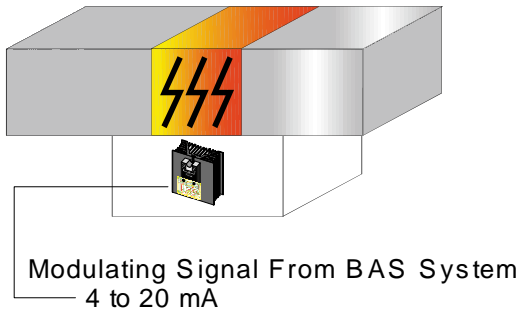

4 mA = 0% capacity
20 mA = 100% capacity

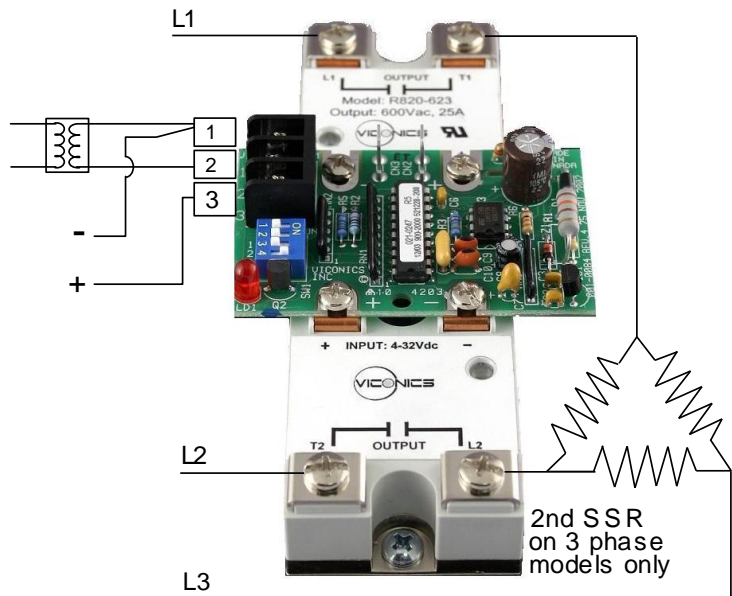

24 Vac Power & Wiring

- It is not necessary to ground any leg of the transformer to earth with the controller card.
- The controller uses internally a half wave rectifier bridge. On 0 to 10 Vdc control signal, the reference of the control signal is the Common of the power supply of the SCR controller card.
- Use a Class 1 (properly fused) or Class 2, CSA or UL recognized transformer.

High voltage Wiring

General cautions:

- High voltages are present on the terminals of these devices. Please read all the instruction in this manual carefully.
- The 45 & 75 Amps models need to be wired with the supplied high voltage lugs. **Attach the wire to the lug first**, and then screw the lug to the power module.
- Have the wiring done by a qualified and skilled professional.
- High voltage and amperage can be fatal.
- All wiring must conform to national electrical code regulations.
- The instrument must be wired before applying power.
- Protect circuits with semi conductor fuses.
- For in panel installation, derating amperage curves are available from the factory.

Specifications

Operating Conditions: 0°C to 80°C (32°F to 176°F) / 0 % to 95 % R.H. non-condensing
See power derating curves document

Thermostatic protection: Self-resetting. Auto shut off when SCR ambient temp. is above 82°C (180°F)

Power supply: 24 Vac -15%, +10% 50/60 Hz; 2 VA
 Use a Class 1 (properly fused) or Class 2, CSA or UL recognized transformer.

Troubleshooting

	Check
1	Check general wiring, as per heater manufacturer diagram Be sure you understand the system and its normal operation
2	Verify high voltage power supply wiring Verify that correct voltage is present at the heater with proper wire size
3	Verify low voltage 24 Vac power supply wiring 24 Vac is present at terminals 1 & 2 of the R820 SCR
4	Create or simulate 100 % heating demand Using present control system
	R820 Configured for 0 to 10 Vdc input signal <ul style="list-style-type: none"> • Signal between terminals 1 & 3 is 10 Vdc or superior • Dip switch properly configured: S1=Off, S2=Off, S3=Off & S4=On • Be sure that the polarity is correct and not reversed + to +, - to - • Red status LED on SCR is on 100 % of the time
	R820 Configured for 4 to 20 mA input signal <ul style="list-style-type: none"> • Signal between terminals 1 & 3 is 20 mA or superior • Dip switch properly configured: S1=Off, S2=Off, S3=On & S4=Off • Be sure that the polarity is correct and not reversed + to +, - to - • Red status LED on SCR is on 100 % of the time
	R820 Configured for 0 to 135 Ω input signal <ul style="list-style-type: none"> • Signal between terminals 1 & 3 is 135 Ω or superior • Dip switch properly configured: S1=On, S2=On, S3=Off & S4=Off • Red status LED on SCR is on 100 % of the time
5	Verify amperage consumption of the heater Red status LED on SCR is on 100 % of the time
6	Verify & correct 24 Vac power supply to the SCR Verify low voltage fuses, protections, flow switch, etc.....
7	Verify control wiring & control signal Correct control signal is present at the SCR Check polarity of control signal
8	Verify fuses & all protections & contact the heater manufacturer



Important Notice:

These instruments have undergone rigorous tests and verifications prior to shipment to ensure proper and reliable operation in the field. However, like other such products, they are subject to failure. It is therefore the responsibility of the installer / user / electrical panel designer to incorporate safety features and devices (such as relays, flow switch, thermal protections, etc..) to protect the entire system from catastrophic failure.